



Lagisza 460 MWe Supercritical CFB – Design, Start-up and Initial Operation Experience

Timo Jäntti
Riku Parkkonen
Foster Wheeler Energia Oy
Finland

Presented at
Power Gen Asia
Bangkok
Thailand
October 7 – 9, 2009

TP_CFB_09_16

**Łagisza 460 MW_e Supercritical CFB -
Design, Start-up and Initial Operation
Experience**

**Timo Jäntti, Riku Parkkonen
Foster Wheeler Energia Oy
Finland**

ABSTRACT

Circulating fluidized bed (CFB) technology has established its position as a utility-scale boiler technology. When considering either new plants or repowering old plants, efficiency and environmental issues are the key issues. High efficiency means lower fuel consumption, and lower levels of ash and emissions, including lower emissions of carbon dioxide (CO₂). To achieve these goals supercritical steam parameters have been applied. First CFB power plant to utilize the supercritical steam parameters with once-through steam cycle technology is Łagisza, 460MW_e in Poland.

In March 2003, A Polish utility company Południowy Koncern Energetyczny S.A. (PKE), at that time Poland's largest utility, selected Foster Wheeler as the boiler supplier for a 460MW_e once-through supercritical, coal fired power plant for Poland. The project received full notice to proceed (NTP) at the end of 2005. CFB was found to be the most cost-effective option for PKE's new power plant over the pulverized coal (PC) technology, enabling them to select any coal they like to burn in the new CFB. The Foster Wheeler design also includes an option to burn coal slurry.

Boiler design for Łagisza power plants utilizes low mass flux BENSON vertical once-through technology developed and licensed by Siemens AG, Germany. CFB boiler with low and uniform furnace heat flux is extremely well suited for the Benson technology. The Łagisza supercritical OTU CFB plant will combine high plant efficiency with the well-known benefits of CFB technology, such as superior fuel flexibility, inherently low emissions and high availability.

Łagisza OTU CFB power plant was handed over to customer at end of June 2009. The paper describes the Łagisza supercritical boiler concept, main technical solutions and the start-up and Initial operation experience of the world first supercritical OTU CFB projects Łagisza.

1 INTRODUCTION

The target for high efficiency in modern power plants is set not only because of economical reasons but also for enhanced environmental performance in terms of reduced fuel needs, quantity of ash generated and pollutants emitted. Cutting CO₂ -emission has become increasingly important after the Kyoto Protocol. As coal will remain an important source of

energy the focus has been set to improve the efficiency of coal fired power plants. To achieve this goal, supercritical steam parameters have been applied. Most large European thermal power plants built for fossil fuels such as coal and brown coal over the last decade have had supercritical steam parameters and have been based on pulverized coal (PC) fired once-through boiler technology.

Circulating Fluidized Bed (CFB) boiler technology has been growing in size and number over the past three decades and it has established its position as utility scale boiler technology. Plant sizes up to 340 MW_e are in commercial operation today, the 460 MWe Łagisza CFB plant with supercritical steam parameters is in startup today and Foster Wheeler is developing supercritical CFB designs up to 800 MW_e in size. A Polish utility company Południowy Koncern Energetyczny SA (PKE) placed an order to Foster Wheeler Energia Oy for a 460 MW_e supercritical CFB boiler for their Łagisza power plant. Contract was signed at the end of year 2002 and now this project for building world's first supercritical once-through CFB boiler is about to be finalized. This is a result of continuous and determined development work conducted by Foster Wheeler including an experience database of over 350 reference boilers in operation.

In 2001, PKE announced a bidding process for supercritical once-through boiler delivery for 460 MW_e unit in their Łagisza plant, with two alternative combustion technologies: pulverized combustion and circulating fluidized bed combustion. Foster Wheeler submitted proposals for both combustion alternatives. Both boiler proposals were based on BENSON technology with vertical tubing and low mass flux. Foster Wheeler was selected as the boiler supplier on December 30, 2002, with both combustion technologies. Finally CFB technology was chosen by PKE for Łagisza OTU boiler after additional two months of detailed technical comparisons, as well as economical studies with following conclusions:

- Total plant investment cost is lower for CFB alternative. The installation of wet desulfurization and SCR systems that are essential for a PC-based solution can be eliminated, and all emissions requirement are still fulfilled.
- Overall plant performance is better. Net plant efficiency using CFB technology and an advanced flue gas heat recovery system is approximately 0.3 %-unit better than with PC solution with similar heat recovery system.

- Fuel flexibility provides a useful safety margin for the future. The unique multi-fuel capability of the CFB boiler provides a wider fuel range and the additional possibility of using opportunity fuels.

In spite of achieving this remarkable milestone the development of the CFB technology is continuing to even larger plant sizes. Boiler designs in size range of 800 MW_e are being developed and will be ready for commercial proposals in near future.

2 LAGISZA PROJECT

The new 460 MW_e (gross) unit will replace old power blocks of Łagisza Power Plant. The existing blocks were erected in 1960's and consist of seven units (110-125 MW_e each). Two of them will be shut down soon after the hand over the new 460 MW_e unit. The new boiler is located adjacent to the old boilers and many of existing plant systems like coal handling and water treatment plant are renovated and utilized for the new CFB unit.



Figure 1 New 460 MW_e Łagisza CFB OTU Unit

Foster Wheeler's delivery comprises turnkey boiler island including engineering and design, civil works and foundations for the boiler, boiler house enclosure with steel structures, boiler pressure parts, auxiliary equipment, main steam piping to turbine and reheated steam piping, coal bunkers and fuel feeding equipment, electrostatic precipitator and cold end flue gas heat recovery system, erection, construction, start-up, and commissioning. The time schedule of the project is presented in Table 1.

Table 1 Project execution schedule

Contract Signing	December 30, 2002
Notice to Proceed:	
I Stage – Basic Engineering	March 1, 2003
II Stage – Execution	December 31, 2005
Hand Over	38,5 months after start of Stage II

Main fuel for the boiler is bituminous coal. The source of fuel consists of 10 local coal mines with wide range of coal parameters, proving once more the fuel flexibility of the CFB technology. Table 2 is presenting parameters of design fuel and overall fuel range.

Table 2 Fuel specification

		Bituminous Coal	
		Design fuel	Range
LHV (a.r.)	MJ/kg	20	18 - 23
Moisture	%	12	6 – 23
Ash (a.r.)	%	23	10 - 25
Sulfur (a.r.)	%	1.4	0.6-1.4
Chlorine (dry.)	%	< 0.4	< 0.4

a.r. = as received

The steam parameters for the boiler were specified by the PKE. The selected steam pressure and temperature are proven in other supercritical units and conventional boiler steel materials can be used. Table 3 presents main design steam parameters of this 460 MW_e CFB boiler.

Table 3 Design Steam parameters at 100 % load

SH flow	kg/s	361
SH pressure	MPa	27.5
SH temperature	°C	560
RH flow	kg/s	306

RH pressure	MPa	5.48
Cold RH temperature	°C	315
Hot RH temperature	°C	580
Feed water temperature	°C	290

The plant net efficiency is naturally dictated by the selected steam parameters, steam cycle configuration, cooling tower conditions and boiler efficiency. In Łagisza design the boiler efficiency is improved by flue gas heat recovery system, which cools the flue gases down to 85 °C thus improving the plant net efficiency. The calculated net plant efficiency for Łagisza is 43.3 % and net power output is 439 MW_e.

The emission requirements for Łagisza boiler are according to European Union directive for Large Combustion Plants (see table 4). The emissions for sulfur dioxide are controlled with limestone feeding into the furnace. With design coal a sulfur reduction of 94 % is required and that is easily achieved with a limestone feeding into the furnace. The nitrogen oxide emissions are controlled with low combustion temperature and staged combustion. There are also provisions made for a simple ammonia injection system (SNCR), however that is not planned to be used with design coals. Particulate emissions are controlled by electrostatic precipitator.

Table 4 Emission limits

Emission (6% O ₂ , dry)	mg/m ³ n
SO ₂	200
NO _x	200
Particulates	30

3 LAGISZA OTU CFB BOILER DESIGN

The boiler design for Łagisza design is based on well proven Foster Wheeler CFB – technology. It utilizes the experience of over 350 reference units starting from the first generation CFB boilers with conventional uncooled cyclone designs which typically had thick multi-layer refractory linings. These heavy refractory linings are known to cause high

maintenance, decreased availability and limiting operational flexibility, such as long start-up times.

The design of the new Łagisza boiler is based on Foster Wheeler's second-generation CFB technology, with the solids separators built from water- or steam-cooled panels integrated with the combustion chamber. This kind of cooled separator design does not require the heavy refractory linings necessary with first-generation uncooled separators. Also the number and size of expansion joints are minimized and for newer water cooled separator designs, no expansion joints are needed at all. The first of the second generation CFB boilers was started already 1992 and thereafter the number and size of this advanced technology grown steadily. The largest of the second generation CFB boiler prior to Łagisza are the units delivered to Turow power plant in Poland for units 4, 5 and 6. The power output of these units is 262 MW_e.

3.1 Water and Steam Circuitry

In the Łagisza CFB boiler the feed water enters the boiler at a temperature of 290 °C for preheating in a bare tube economizer. Thereafter water is divided to the enclosure walls of the INTREX™ fluidized bed heat exchangers and further to distribution headers of the evaporator (furnace) walls. The water is heated in the evaporator wall tubes and eventually converted to superheated steam before the evaporator outlet. Therefore there is dry-out occurring (as in all once through designs) at a certain elevation of the evaporator causing a decrease internal heat transfer coefficient and locally increased tube and fin temperatures. In CFB boilers the furnace heat flux is considerably lower than in PC boilers and the highest heat flux occurs in the lower furnace where water is always sub cooled. Detail studies have proved that in CFB conditions proper cooling of the evaporator wall tubes is achieved at wide load range using normal smooth tubes with mass flux of 550 – 650 kg/m²s at full load.

During boiler start-up and shut down a circulation pump is used to ensure minimum water flow through the evaporator. The two-phase flow from the outlet headers of the evaporator walls is collected into vertical water/steam separators where the water is separated from the steam and led to a single the water-collecting vessel, see figure 2.

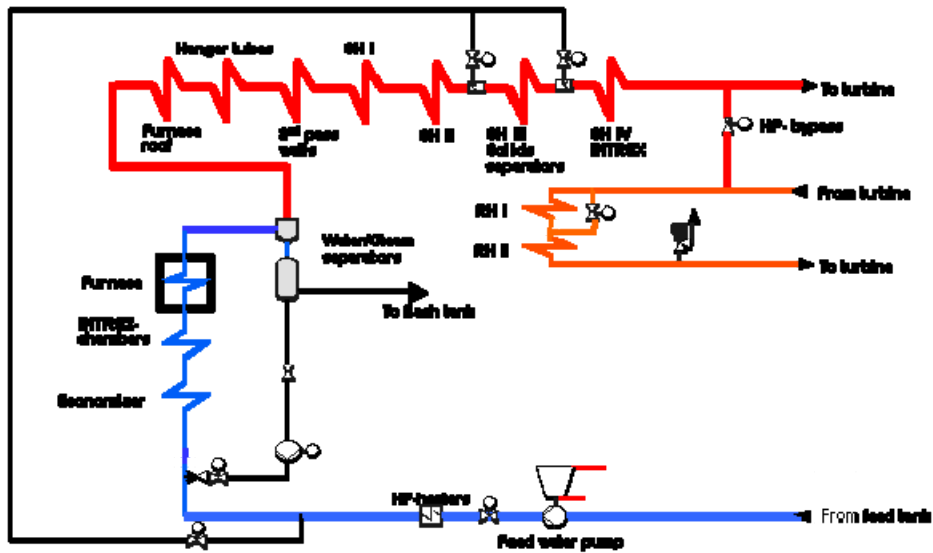

Figure 2 Steam circuitry

When the boiler load exceeds the so called BENSON point at approximately 32 % load the steam exiting the evaporator walls is slightly superheated. Hence the circulation system can be closed and the boiler has achieved once-through operation mode.

Dry steam from the water/steam separators is led to the furnace roof which is the first part of superheating system. Then the furnace roof steam is taken to superheater support tubes, walls of the convection pass and tube coils of the convective superheater I. Superheater II is located in the upper furnace in areas where the solids densities are low and its lower ends are protected against any possible erosion.

After superheater II the steam is divided to eight parallel solids separators that form the superheater III. The separator walls are formed of the gas tight membrane walls and they are covered with a thin refractory lining with high heat conductivity.

Final superheating is performed in superheater IV located in four INTREX superheaters at the one side of the furnace. The INTREX superheater is a fluidized bed heat exchanger that is integrated to the lower part of the furnace. The main steam temperature is controlled with a two stage feed water spray as well as by adjusting fuel feeding.

Steam after the high pressure turbine is brought back to the boiler for reheating. The first stage reheater is located in the convection pass. The reheater I (RH I) is equipped with a steam side bypass which is used for reheat steam temperature control. At higher loads part of

the reheat steam is bypassed the RH I which reduces the heat pick-up and hence the inlet steam temperature to RH II is decreased. This patented reheat steam control method avoids using a spray control for reheat side and therefore do not cause a decrease in plant efficiency. There are over 20 CFB boilers utilizing this control method, e.g. Turow CFB boilers in Poland. In Łagisza the final reheater stage is located in INTREX heat exchanger similar to the final superheater.

The plant is operated with sliding steam pressure so the boiler pressure is following the turbine load. Hence at lower loads (below 75 %) the main steam pressure below critical pressure (221 bar) and at higher loads the boiler is operating at supercritical pressures.

3.2 Furnace Design

From the flue gas side, Łagisza's furnace design is based on extensive analysis of all the fuels and limestones that are going to be used. These have given the required data for the design models to make predictions for circulating material particle size distribution, solids densities and finally the heat transfer with gas temperatures. The design resulted with a furnace cross section of 27.6 x 10.6 m and height of 48.0 m. The Łagisza CFB boiler is presented in figure 3.

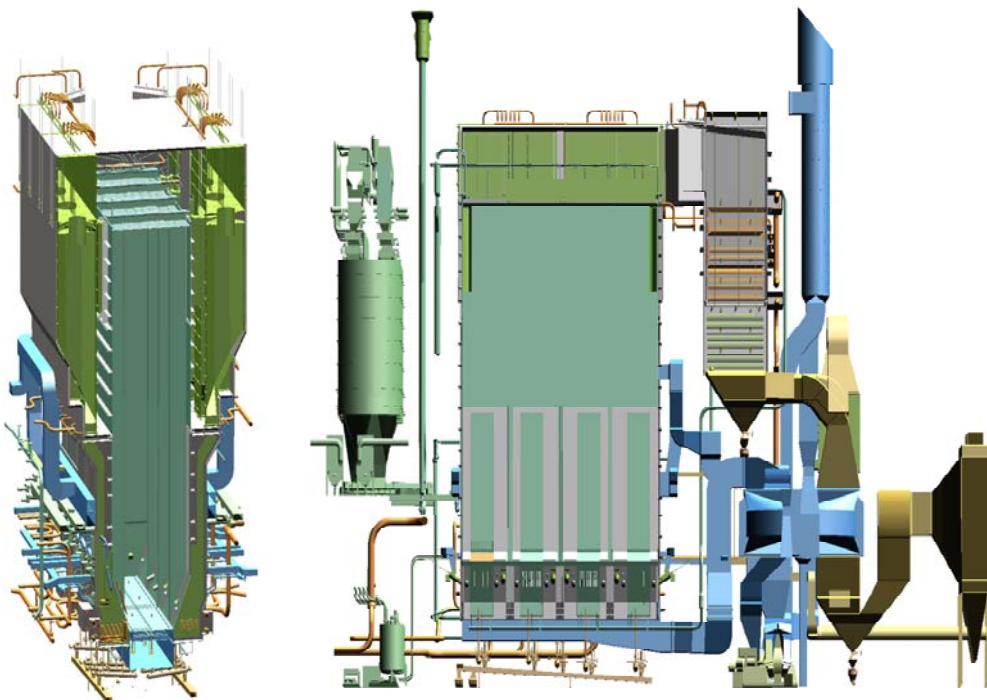

Figure 3 Łagisza CFB Boiler

A single fluidizing grid is utilized in the bottom of the furnace under which there are four separate air plenums introducing primary air to furnace. The primary air flow for these four air plenums is measured and controlled separately to insure equal air flow to all sections of the grid and uniform fluidization. The single continuous fluidizing grid ensures simple control as well as a stable and uniform operation of the furnace.

Fuel is introduced to the side walls of the furnace via fourteen feeding points giving the same grid area per feed point as used in other boilers. Secondary air is introduced also on long furnace walls at three elevations to provide staged combustion for minimizing the NO_x emissions.

3.3 Solids Separator Design

The solids separator design for Łagisza CFB boiler is based on the second generation CFB design with steam cooled panel wall construction. The solids separator design is optimized for high collection efficiency with low flue gas pressure loss. The advanced separator inlet design with tall and narrow shape provides a uniform flow of flue gas and solids avoiding high local velocities. This results in equal collection efficiency as the best conventional cyclones with considerably lower pressure loss. There are eight (8) solids separators arranged in parallel, four (4) separators on two opposite furnace walls.

The separators are designed with panel wall sections and have a thin refractory lining anchored with dense studding. This minimizes the required amount of refractory. The separators are manufactured with panel welding machines eliminating need for extensive manual welding. The separator tubes are steam cooled forming a third superheater stage. Also the cross over ducts (two pcs) after the solids separators are steam cooled and connected to the separator tubing.

3.4 Auxiliary Equipment

Combustion air system for Łagisza boiler consist of primary and secondary air system and separate air system for fluidizing the INTREX heat exchangers and sealing devises. Radial fans with inlet guide vane control are used for primary and secondary air fans, 2 pcs each. For induced draft (ID) fans two axial fans are used. A flue gas recirculation system is provided to accommodate the larger variations in the fuel quality.

Downstream the economizer flue gases are cooled in a tri-sector rotary air heater and in a parallel by-pass economizer. The tri-sector air heater was selected over a quad-sector

alternative due to its smaller diameter of the heat surface, shorter sealing length and better mechanical rigidity.

Electrostatic precipitator (ESP) with four electrical fields in series is used to control dust emissions to 30 mg/m³n. The separated fly ash is conveyed to fly ash silo using a dense phase ash conveying system.

Fuel handling equipment includes a coal screening and crushing station located at the fuel yard. The system consists of 2 x 100 % lines having a capacity of 900 t/h. Each line has a primary and secondary roller screen and a granulator type crusher. With this equipment the fuel is crushed to a maximum size of 8 mm.

Coal feeding system consists of four similar fuel feed lines, two fuel feed lines at both of the long walls of the furnace. One fuel feeding line includes fuel day bin (1 000 m³), drag chain feeder, drag chain conveyor and discharge to the feeding points. Each feed point has a dosing screw, slide gate and wall feeding screw.

3.5 Flue Gas Heat Recovery System

The flue gas Heat Recovery System (HRS) improves the boiler and power plant efficiency by decreasing the flue gas temperature down to 85 °C. The system recovers heat from the flue gases which results in an improvement of about 0.8 %-units in total plant efficiency.

HRS is operating in the clean gas after the ESP and ID fans. The cooling of the flue gas takes place in a heat exchanger made of PF-plastic tubing to avoid corrosion problems. After the HRS, the flue gas is conducted to the cooling tower via a fiberglass duct.

A primary water circuit transfers the recovered heat to the combustion air system and heat is transferred to both primary and secondary air. As the combustion air temperature before the rotary air preheater is increased, the incoming cold combustion air flow is not able to absorb all the heat available from the flue gases. Therefore part of the flue gases is conducted to a separate low-pressure bypass economizer where the heat from the flue gases is used for heating of the main condensate.

4 COMMISSIONING STATUS

4.1 Cold Commissioning

Erection works in the Łagisza boiler island were mostly completed on July 2008 and mechanical completion was achieved on 29th of August, exactly according to project schedule. Cold commissioning of the boiler plant started in middle of the July simultaneously with last minor erection work still ongoing. During cold commissioning flushing of all necessary pipelines with water, air or steam was done, correct operation of the electric motors, fans, control dampers, valves, and instrumentation was verified and loop tests completed. All the systems and devices of the boiler plant were checked after erection works and made ready for the trouble free start of chemical cleaning and hot commissioning.

4.2 Hot Commissioning

First Firing and Acid Cleaning

First firing took place in 28th of August 2008 followed by acid cleaning started on 19th of September and completed on 1st of October. After restoration works boiler was ready for the magnetite film formation. Process of magnetite film formation was successfully completed between 30th and 31st of October.

A lot of time was saved by using three of the boiler coal silos as temporary 3000 m³ water reservoir during acid cleaning process. Whole boiler excluding RH II was included in acid cleaning and as the cleaning and magnetite film formation were finished boiler was prepared for the start of the steam blowing.

Steam Blowing

Blow-out process in Łagisza was carried out continuously during the daytime lasting up to 4 hours with proper Disturbance Factor (DF). Boiler HP and RH parts were steam blown simultaneously meaning that steam leaving from boiler HP part was led to the cold reheat and through the reheaters up to hot reheat and onwards via temporary pipeline and silencer to the atmosphere. This kind of blow-out process requires a lot of make-up water and was made possible by using the coal silos as a temporary water reservoir.

On 13th of November the plant was ready for the start of the steam blowing and boiler loading could be increased following the refractory curing curve and making light steam blowing with

low DF. On 20th of November first steam blowing with proper DF and targets was accomplished. Continuous blow-out was found effective as steam blowing were finished and required cleanness of steam pipelines achieved on 1st of Dec. after just seven blows.

During the steam blowing coal was co-fired with Light Fuel Oil (LFO) in Łagisza boiler for the first time. Load of ~40 %-MCR was achieved and furnace temperature increased up to 700 °C. Once-Through (Benson-point) mode was also achieved for the first time during the blow-out process.

By-pass Operation

Restoration works after blow-out took around two weeks. After finishing all the necessary works, by-pass operation of the plant was started meaning that HP- and LP-by-pass stations were utilized in order to get condensate back to the process and condensate system cleaned up. Part of the condensate was dumped from the cycle to be substituted by clean demineralized water. As the boiler water quality improved a pressure in the boiler was slowly increased. During the course of by-pass operation, preliminary tuning of the boiler controls and sequences was made.

Steam to turbine

Steam was introduced to the turbine for the first time in 7th of February 2009 after which turbine and generator tests were started. For the first time boiler was operated only with coal without LFO firing at about 25 %-MCR load. Due to four fuel feeding lines and numerous feeding points boiler operation with coal was smooth and easily adjustable.

Synchronization

The new 460 MW_e power unit of Łagisza was synchronized to the electrical network for the first time in 15th of February 2009.

Full load operation

On the 10th of March the new Łagisza Unit reached full output power of 460 MW_e. The boiler was shortly operated on once-trough mode with supercritical steam parameters generating 361 kg/s steam (see Figure 4). Commissioning continued with fine tuning of the boiler controls and performance prior to start of a 720 h trial operation.

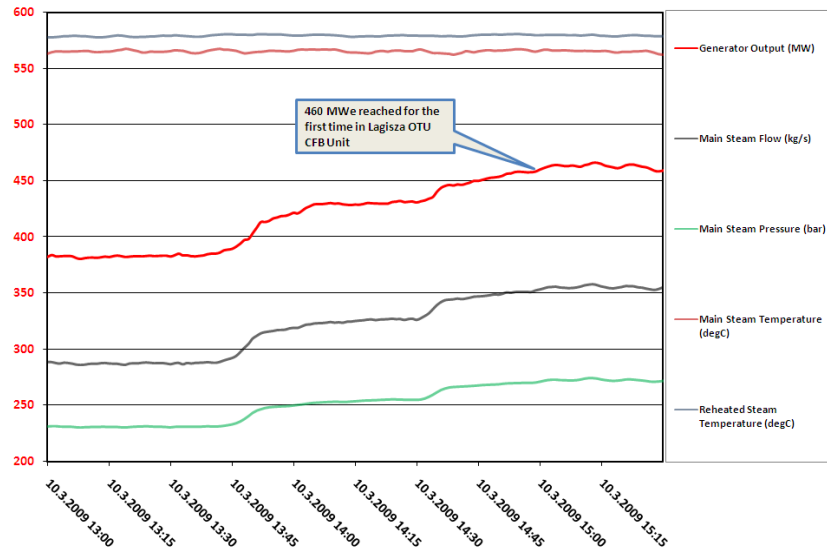

Figure 4 Load increase to MCR for the first time in Łagisza

Hand over

Łagisza CFB power plan was handed over to customer on 27th of June 2009.

5 INITIAL OPERATION EXPERIENCE

Initial operation experience of the Łagisza boiler has been extremely positive. Over the whole load range boiler has performed as designed and operation has been steady and easily controllable. Basic process parameters on different levels of load are shown on following table.

Table 5 Process parameters on different load levels

		40 %MCR	65 %MCR	80 %MCR	100 %MCR
Main steam flow	kg/s	144	235	287	361
Main steam pressure	Bar	131	186	231	271
Main steam temperature	°C	560	560	560	560
Reheat temperature	°C	550	572	580	580
Bed temperature	°C	753	835	853	889
Flue gas exit temperature	°C	80	81	86	88
SO ₂ emission*	mg/m ³ n	143	197	140	<200**
NO ₂ emission*	mg/m ³ n	167	154	188	<200**
CO emission*	mg/m ³ n	45	48	48	22

*@ 6 % O₂, dry

** Demonstrated to be met.

5.1 Evaporator operation

Peak heat fluxes in a CFB boiler are clearly lower than experienced in PC boilers. In the CFB highest heat flux occurs just above the refractory covered zone in the lower furnace. At that level the fluid is at a low temperature at supercritical pressures and is a sub-cooled liquid at reduced loads (sub-critical steam pressure). Because of the low heat fluxes in a CFB furnace, the full load water-steam mass flow rate can be in the 550 – 650 kg/m²s range. This low mass flux greats a “natural circulation” characteristic that together with stable circulation of the solids giving more uniform heat flux distribution, will result in reduced tube –tube temperature differentials.

Based on the analysis result from Łagisza CFB, heat flux profiles to furnace walls have been low and uniform during coal firing. Highest heat fluxes have been measured above the

refractory lining in lower furnace as it was expected. Due to uniform heat fluxes to furnace walls, steam temperature variation after evaporator has been minimal when operating above Benson-point.

5.2 Process behavior

Fuel flexibility, high combustion efficiency and low emissions are well known advantages of CFB boilers. In this point of view, once-through CFB boiler does not differ from drum boiler. Łagisza boiler has shown an excellent environmental – and economical performance as it has been operated on full load range firing coal. Emissions have been lower than set by the on Large Combustion Plant (LCP) directive and a low flue gas exit temperature together with good combustion efficiency are guaranteeing high thermal efficiency.

Control concept chosen for the Łagisza boiler has turned out to be a success. Boiler is behaving well on transient conditions and on the other hand all the parameters are extremely stable as the boiler is operated on steady state conditions.

5.3 Mechanical scale up

The boiler's general layout was based on the conventional in-line arrangement that has been applied in Units 4 – 6 at the Turów power plant. Mechanical scale up was also reasonable modest since physical size of the Łagisza boiler is not significantly bigger than boilers already in operation for lower grade fuels like brown coal in Turów units. No problems regarding mechanical scale up of the boiler occurred during commissioning.

5.4 Auxiliary equipment operation

Boiler auxiliary equipments have worked without major problems from minimum up to maximum boiler load.

5.5 Field Testing

As Foster Wheeler is heading for larger boiler sizes and higher efficiencies it is important to collect all possible information from Łagisza to achieve a better understanding of large CFB boilers.

On course of the boiler commissioning and trial operation Foster Wheeler carried out an extensive testing program on the Łagisza boiler. Performance of the boiler was tested on steady state operation as well as in dynamic conditions and data from the measurements will be used for validation of the process –and dynamic models for large scale CFB.

6 SUMMARY

Circulating fluidized bed (CFB) technology has established its position as a utility-scale boiler technology. When considering either new plants or repowering old plants, efficiency and environmental issues are the key issues. High efficiency means lower fuel consumption, and lower levels of ash and air emissions, including lower emissions of carbon dioxide (CO₂). To achieve these goals, supercritical steam parameters have been applied. First CFB power plant to utilize the supercritical steam parameters with once-through steam cycle technology is the Łagisza, 460MW_e in Poland.

In December 2002, a Polish utility company Południowy Koncern Energetyczny S.A. (PKE), at that time Poland's largest utility, selected Foster Wheeler as the boiler supplier for a 460 MW_e once-through supercritical, coal fired power plant. CFB was found to be the most cost-effective option for PKE's new power plant over the pulverized coal technology, enabling them to select any coal they like to burn in the new CFB.

The Łagisza boiler design is based on well proven Foster Wheeler CFB –technology. The design of the new Łagisza boiler is based on Foster Wheeler's second-generation CFB technology, with the solids separators built of steam-cooled panels integrated with the combustion chamber. Łagisza boiler utilizes low mass flux BENSON vertical once-through technology developed and licensed by Siemens AG, Germany. CFB boiler with low and uniform furnace heat flux is extremely well suited for the Benson technology.

Erection works of the boiler plant were mostly completed on July 2008 and commissioning could be started. Commissioning of the boiler plant proceeded from cold commissioning to acid cleaning and steam blowing. Steam was taken to the turbine for the first time in 7th of February and synchronization took place in 15th of February. Full output power of the unit, 460 MW_e, was achieved on 10th of March followed by fine tuning of controls and

optimization of the boiler performance. After completing the 720 h trial operation Łagisza OTU CFB plant was handed over to customer on 27th of June 2009.

Operation experiences of the 460 MW_e OTU CFB have been excellent. Boiler operation has been stable and easily adjustable. Heat fluxes to furnace walls on coal firing have been low and uniform as was expected. Adjustability of the large boiler with numerous fuel feeding points has turned out to be good. Mechanical scale up of the Łagisza boiler was quite modest and no problems on that side have occurred either.

For process -and dynamic models validation Foster Wheeler carried out an extensive testing program for the Łagisza plant including testing of the boiler operation and performance in steady state and dynamic conditions. This will confirm the understanding about operation of large CFB as heading up on boiler sizes, steam parameters and efficiency.

Initial operating experiences of the world's first CFB utilizing supercritical steam parameters have been excellent. This provides a good knowledge base for Foster Wheeler to be prepared to propose CFB technology with super-critical steam parameters up to scale 800 MW_e in near future.

REFERENCES

- /1/ Stephen J. Goidich, Song Wu, Zhen Fan, Arun C. Bose: “Design Aspects of the Ultra-Supercritical CFB Boiler” Presented in International Pittsburgh Coal Conference, Pittsburgh, PA, Sept. 12-15, 2005
- /2/ I. Venäläinen; R. Psik: “460 MWe SUPERCRITICAL CFB BOILER DESIGN FOR LAGISZAPOWER PLANT” Presented in P-GEN Europe 2004, Barcelona, Spain, 25 –27 May, 2004
- /3/ T. Jäntti et al.; “Łagisza 460 MWe Supercritical CFB - Design, Start-up and Initial Operation Experience” Presented in P-GEN Europe 2009, Cologne, Germany, 26 –28 May, 2009